

REVIT CONTENT INTRODUCTION & USER GUIDE



Version 2: AUG 2023

CONTENTS

1.0 FAMILY CREATION CONSIDERATIONS	02
2.0 REVIT CONTENT LIBRARY OVERVIEW	03
2.1 Loadable Panel Families.....	03
2.2 Array Ceiling Baffles	03
2.3 Fuji Ceiling Tiles.....	04
2.4 System Families (curtain walls).....	04
2.5 Loadable Material Families	05
2.6 Virtual Showroom/QA Project File.....	10
3.0 TECHNICAL DETAILS	11
3.1 Type Catalog Families.....	11
3.2 Materials Library	12
3.3 Loadable Acoustic Panels.....	13
3.4 Array Ceiling Baffles	14
3.5 Fuji Ceiling Tiles.....	20
4.0 CLOSING STATEMENT	24

This document provides an overview of the Revit content library supplied by Woven Image. The parametric content is all created natively in Revit, allowing users the ability to design and document in a wide range of acoustic solutions.

Also covered in this document is an overview of the Revit content development methodologies used by IGS BIM Solutions in creating the Revit families, ensuring a consistent, robust, and reliable Revit library. Ultimately, the Woven Image Revit families should require minimal, firm-specific localisation/standardisation to become the 'go-to' Revit families when acoustic solutions are required in a Revit project.

Should you require Woven Image options outside the range of products detailed in this Woven Image Revit content library, please contact Woven Image about future ranges to be developed in Revit and one-off requests.

REVIT CONTENT INTRODUCTION & USER GUIDE



1.0 FAMILY CREATION CONSIDERATIONS

Woven Image Revit families have been created to a consistent, high standard with the objective of finding a balance between complexity of use, functionality, documentation output, file size and performance in a project environment. Primary Woven Image Revit content creation insights and considerations are listed below:

- Families supplied in Revit 2019 format.
- Native Revit geometry used throughout, including nested families (e.g. no AutoCAD or SAT files etc.).
- Loadable families have been created with host types appropriate to their use, this is outlined for each family type in Section 2.
- Consistent family and shared parameters have been used sparingly, allowing for Woven Image attributes to be scheduled in the Revit project environment.
- Reference planes have been applied, named, tidied, and set to the correct 'is reference'. Thought has been given to the likely end user requirements in placement/alignment and dimensioning of the families. The origin point has also been applied accordingly.
- Detail level settings applied to 3D geometry and plan views improving model performance.
- All warnings have been reviewed and removed where possible.
- The families have been fully purged and all additional materials, line patterns and fill patterns removed.
- Logical and consistent family and type naming has been applied across all families.
- OmniClass and UniClass classification has been set appropriately.
- The family file sizes have been optimised to be relatively small when the family's overall capabilities are considered, ensuring large Revit projects are not burdened by Woven Image families.

REVIT CONTENT INTRODUCTION & USER GUIDE



2.0 REVIT CONTENT LIBRARY OVERVIEW

2.1 Loadable Panel Families

The Woven Image Revit content library contains a range of loadable 3D family files to satisfy a variety of approaches to documenting the various acoustic panel products. As can be seen below, the embossed panels feature two family files per product range – A single panel family that can be cut down to the desired size (*Panel_Acoustic*), and a line-based family to automate the process of documenting multiple panels side by side (*PanelArray_Acoustic*).

3 x standard EchoPanel®

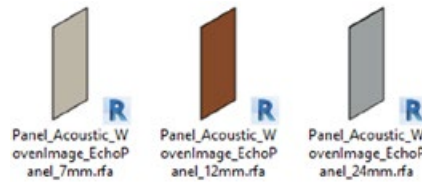

8 x Embossed panels

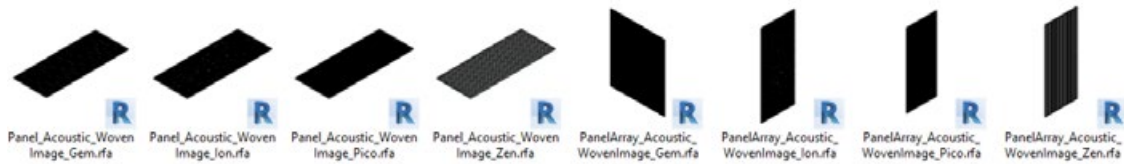

4 x Precision cut panels

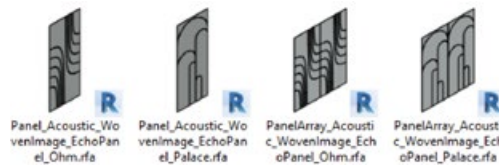

2.2 Array Ceiling Baffles

A series of face-based loadable component families have been created for each of the 9 currently available Array ceiling baffle profiles. Accompanying Type Catalogs allow for ease of loading particular thicknesses and colours.



REVIT CONTENT

INTRODUCTION & USER GUIDE



2.3 Fuji Ceiling Tiles

A series of non-hosted loadable components have been provided to represent the 4 tile profiles within the Fuji range. Default family types allow for swapping between standard colour options within each. A family has been created for each tile size as an assembled arrayable system, with a separate version also being provided for each tile as a standalone component that can be manually placed and rotated on the provided rail family for increased design flexibility.



2.4 System Families (curtain walls)

Curtain wall system families have been supplied for the Ascent tile range. These wall types generate individual system panels at a fixed size based on the desired overall wall height and length. Each panel can be individually referenced and quantified via a curtain panel schedule if desired.

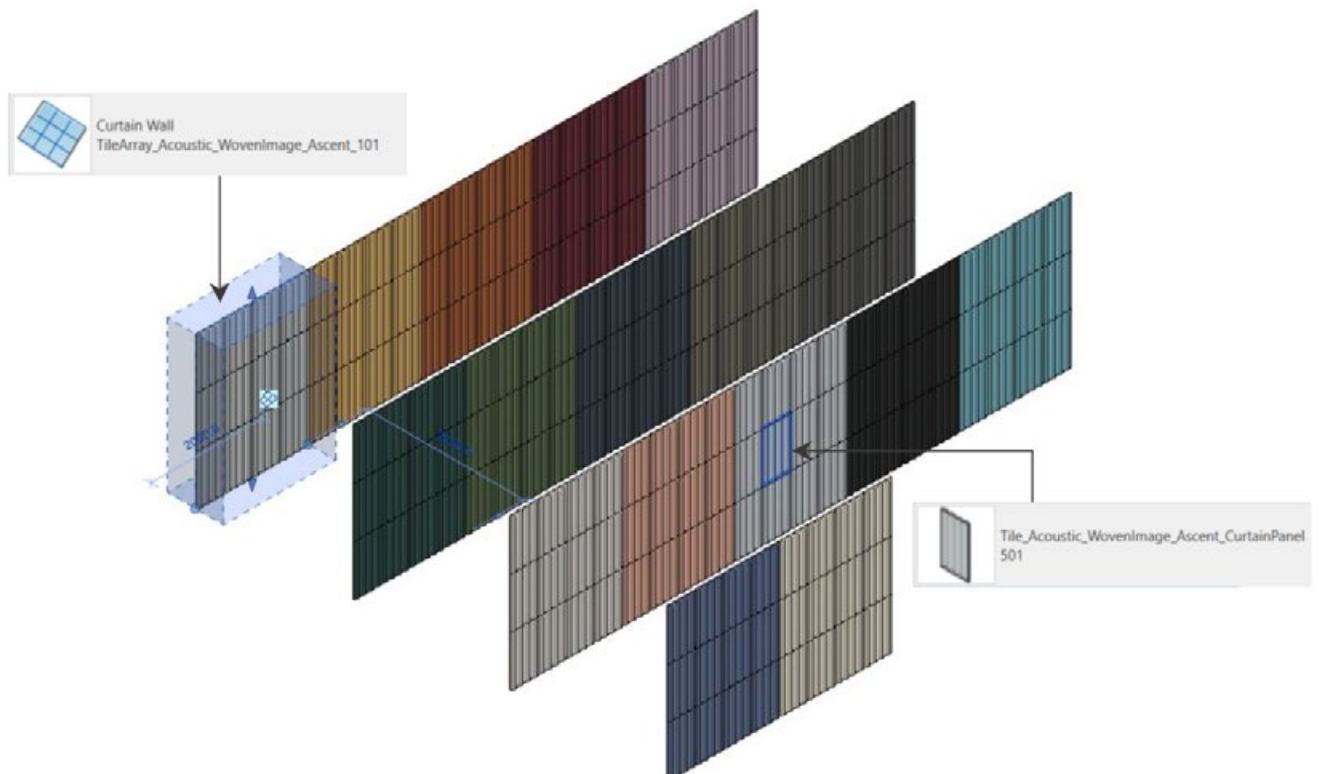

REVIT CONTENT INTRODUCTION & USER GUIDE



2.5 Loadable Material Families

The Woven Image Revit content library contains a suite of loadable generic model components (.rfa), each representing a single colour across the various ranges of acoustic panels and tiles. The materials come pre-configured with hatch patterns and normal maps where appropriate and can be easily copied into an active project for realistic visualisation.

The below sections outline the specific colours available for each product offering:

17 x Ascent tiles

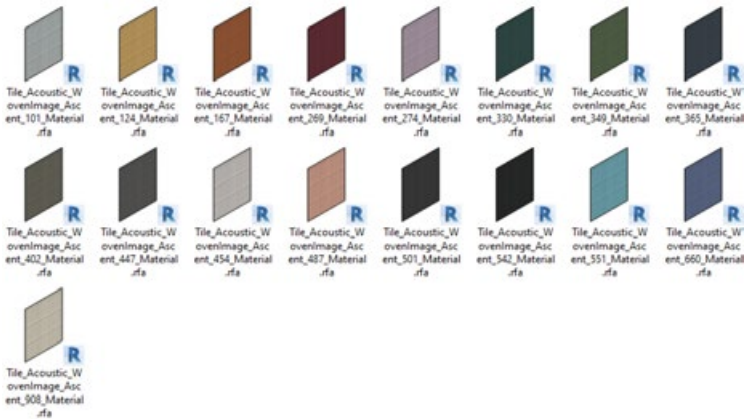

36 x EchoPanel® acoustic panels

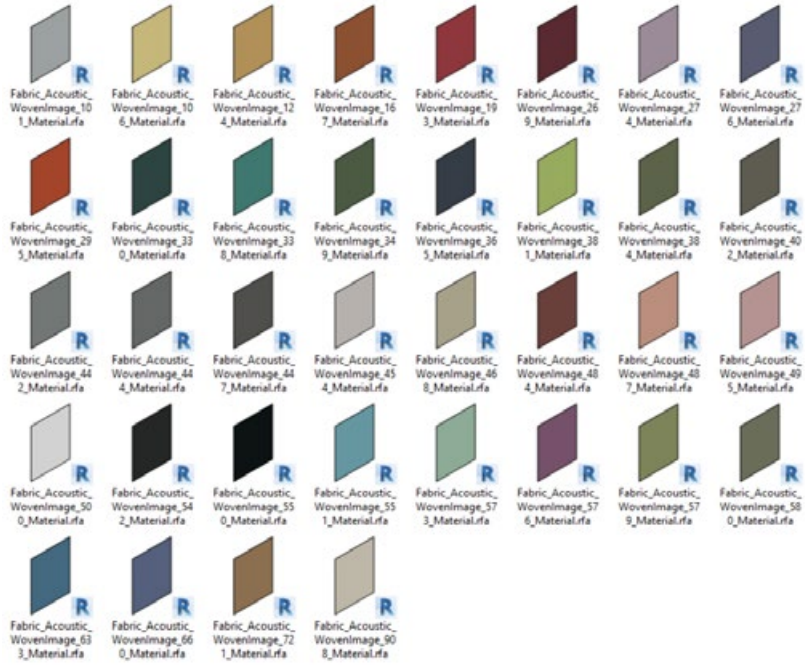

REVIT CONTENT INTRODUCTION & USER GUIDE



36 x EchoPanel® Empire panels

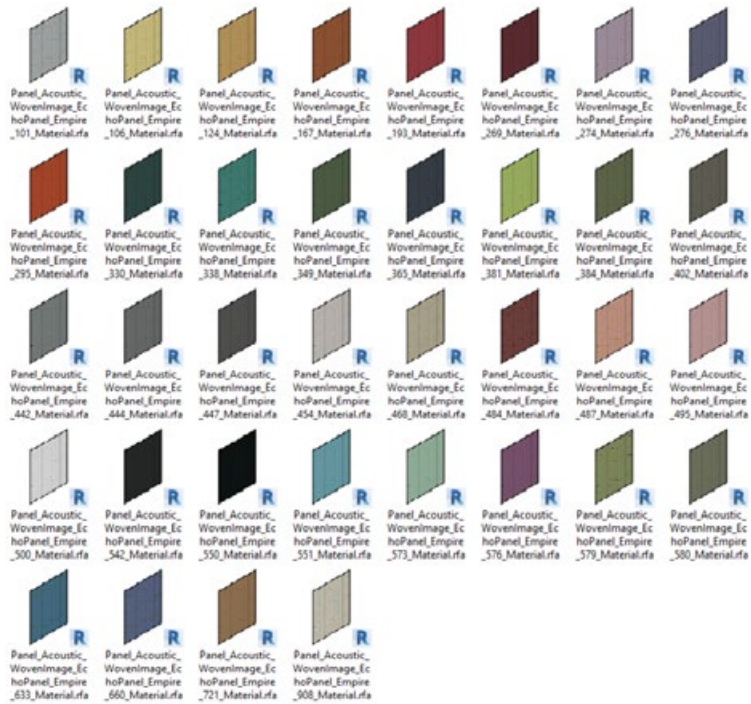

36 x EchoPanel® Latitude panels

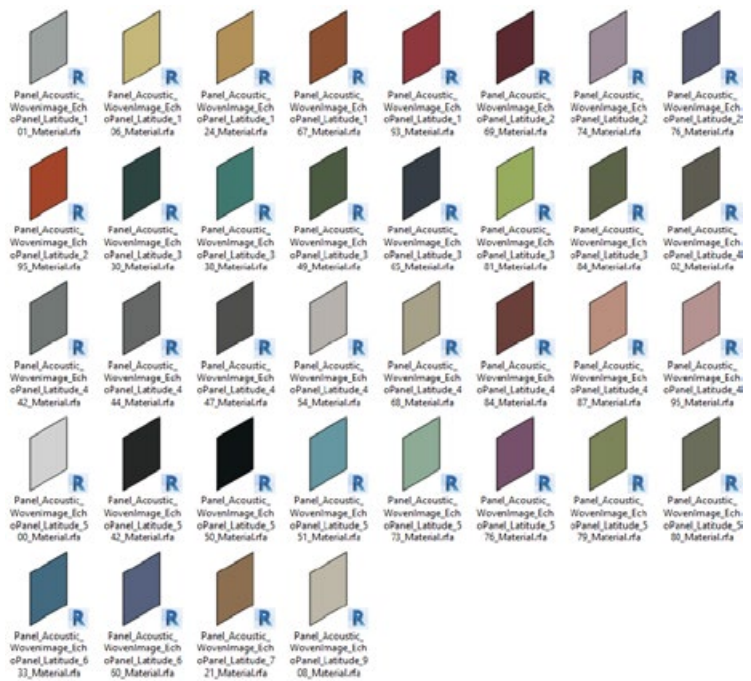

REVIT CONTENT INTRODUCTION & USER GUIDE



36 x EchoPanel® Longitude panels

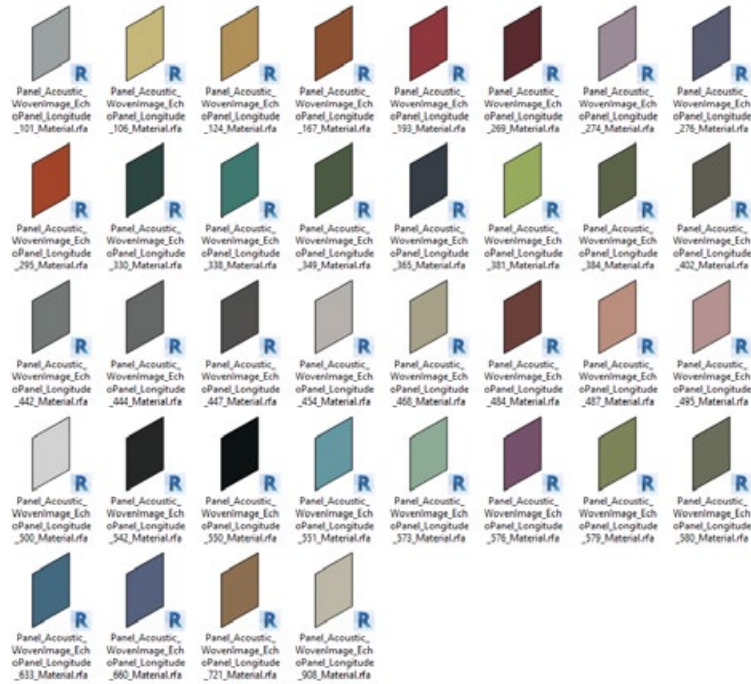

36 x EchoPanel® Meridian panels

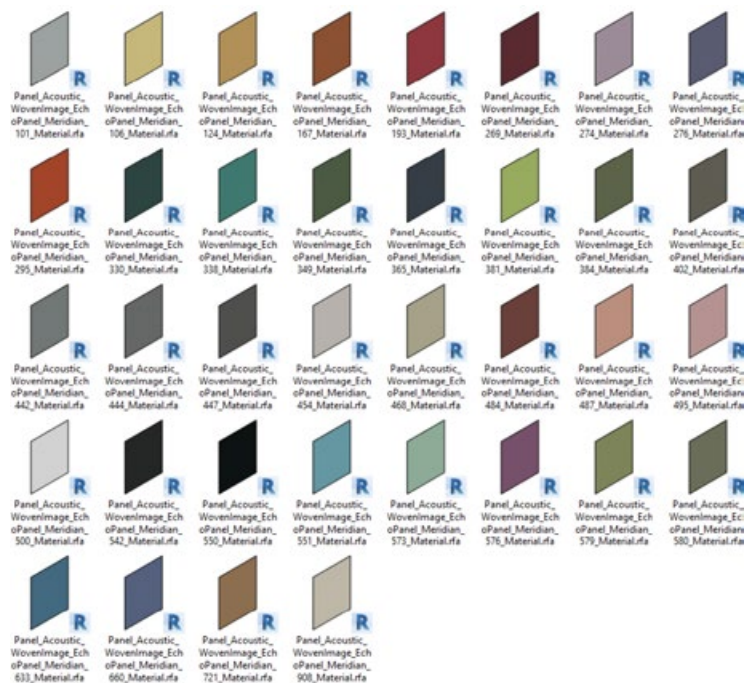

REVIT CONTENT INTRODUCTION & USER GUIDE



36 x EchoPanel® Ohm panels

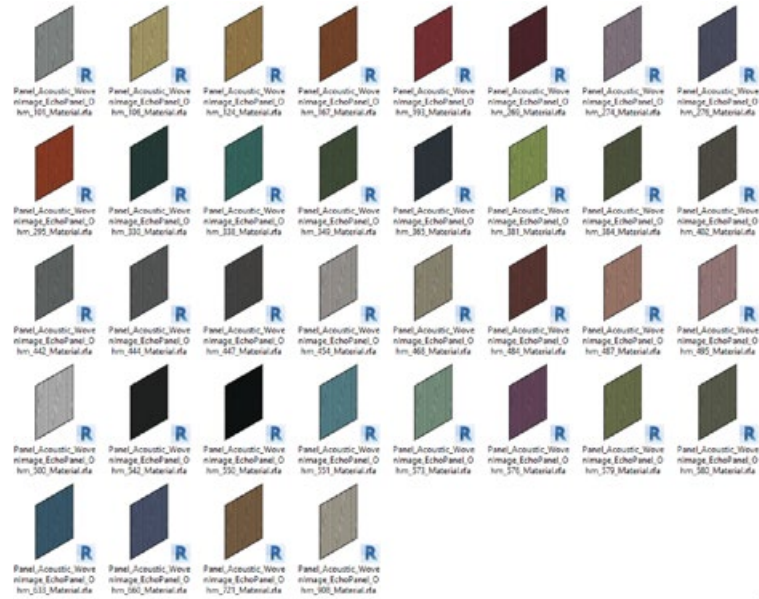

34 x EchoPanel® Palace panels

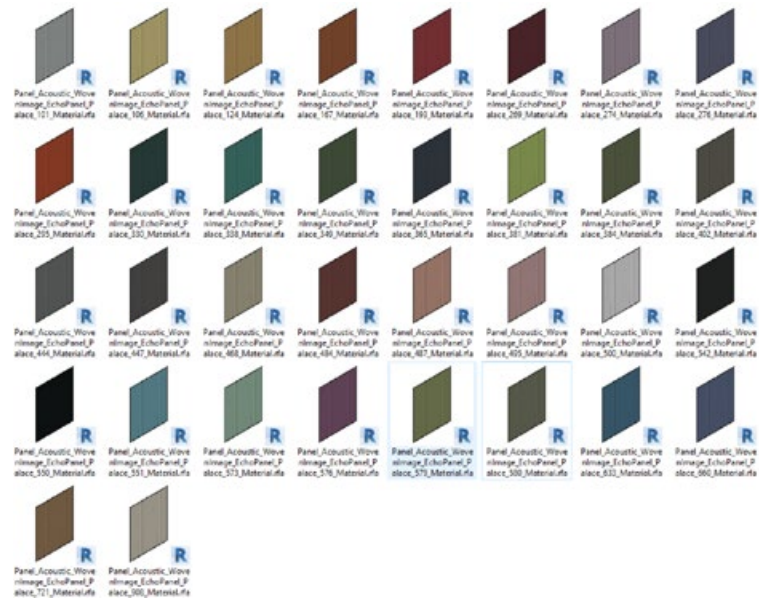

20 x Gem embossed panels

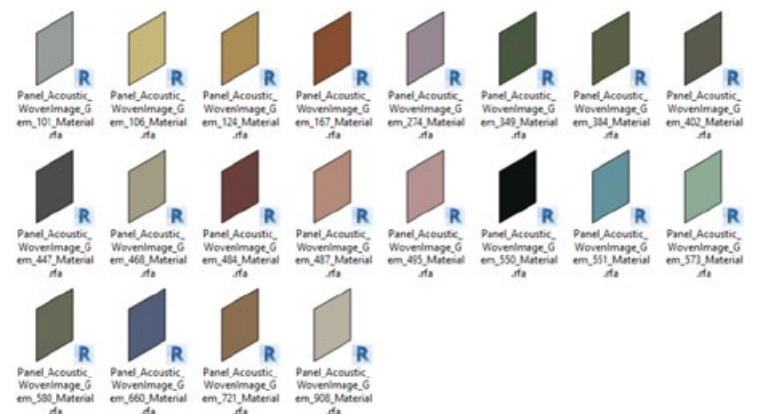

REVIT CONTENT INTRODUCTION & USER GUIDE



20 x Ion embossed panels



25 x Pico embossed panels

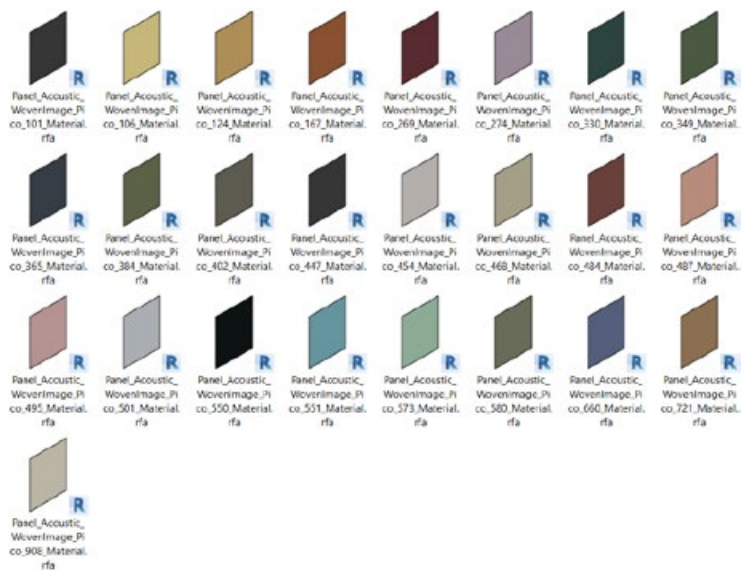

REVIT CONTENT INTRODUCTION & USER GUIDE



25 x Zen embossed panels

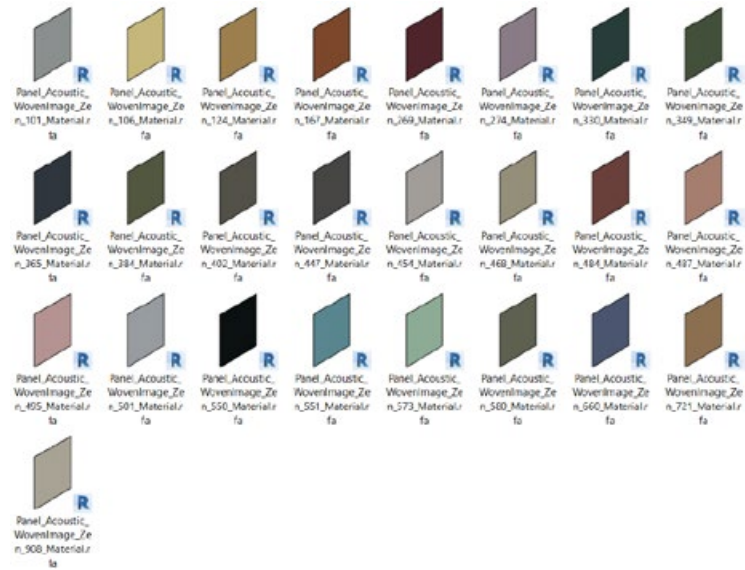

2.6 Virtual Showroom/QA Project File

A sample Revit project has been created that contains all families and types laid out side by side. This project contains sample floor plans, 3D perspectives and a preconfigured schedule allowing Revit users to quickly assess the families' performance in a project environment.

These Revit assets can be 'copied & pasted' into another Revit project as an alternative workflow to loading the separate families into your project.

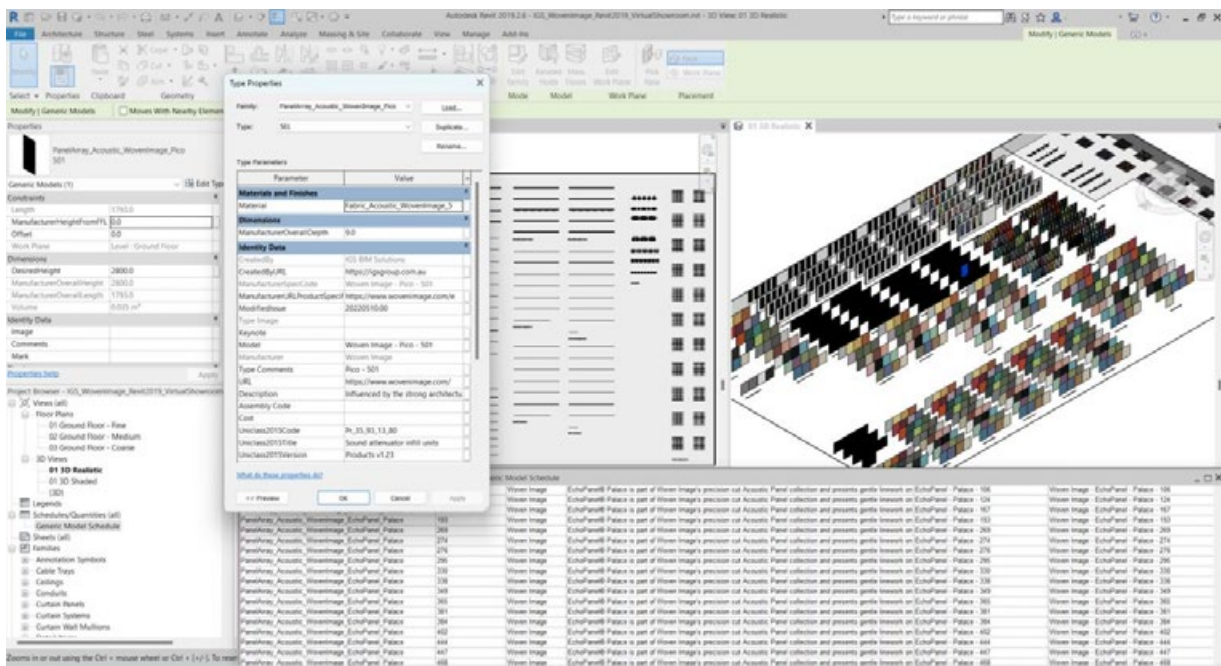

REVIT CONTENT INTRODUCTION & USER GUIDE



3.0 TECHNICAL DETAILS

3.1 Type Catalog Families

To minimise unnecessary types being loaded into a Revit project, all Woven Image Array baffle family files have been created with an accompanying Type Catalog file. When an Array baffle system is loaded into a Revit project, the 'Specify Types' dialog opens. Properties can be filtered at the top to narrow down the selection giving full control over the family types that will be loaded.

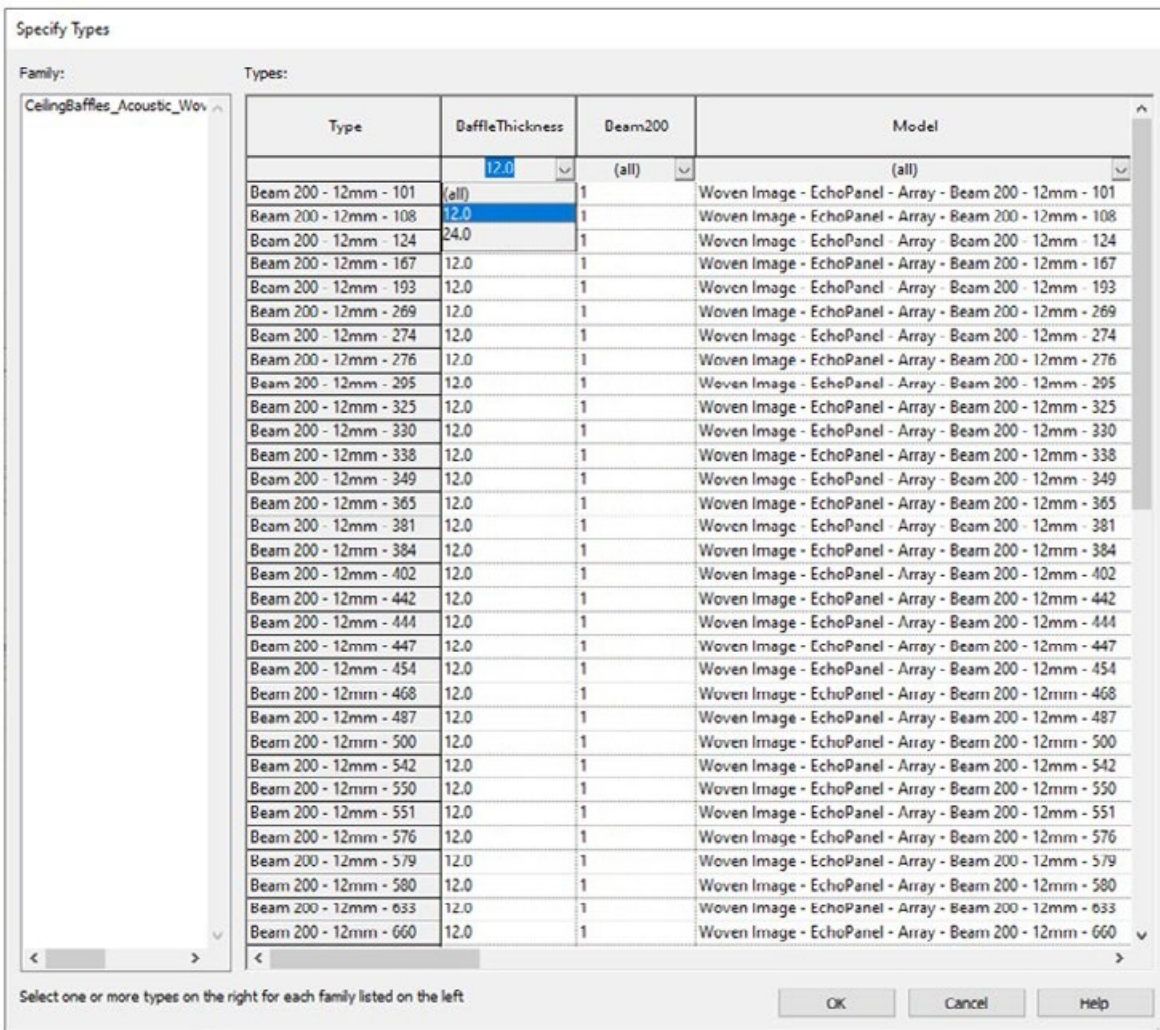

To load a Type Catalog, you must load the family through the Revit ribbon bar 'Insert Family' command and browse to the file location. Dragging and dropping the RFA file into a Revit model will cause Revit to load the family with only a single generic type ignoring the associated Type Catalog list.

- The TXT file must be in the same directory as the RFA file, with the same file name. Take care if moving files into BIM libraries or project folders.
- The RFA family must be opened from a file menu in Revit – not through drag and drop.
- Only load variation you think will be needed to reduce the number of items in the list of available object types.

REVIT CONTENT INTRODUCTION & USER GUIDE



3.2 Materials Library

Basic, non-intrusive materials have been included in the Revit library.

Materials are named with the same hierarchical structure as the families:

<Type>_<Manufacturer>_<Descriptor> to fit in with existing material libraries.

All unused material assets have been deleted from the families, in addition to purging out all material assets where possible.

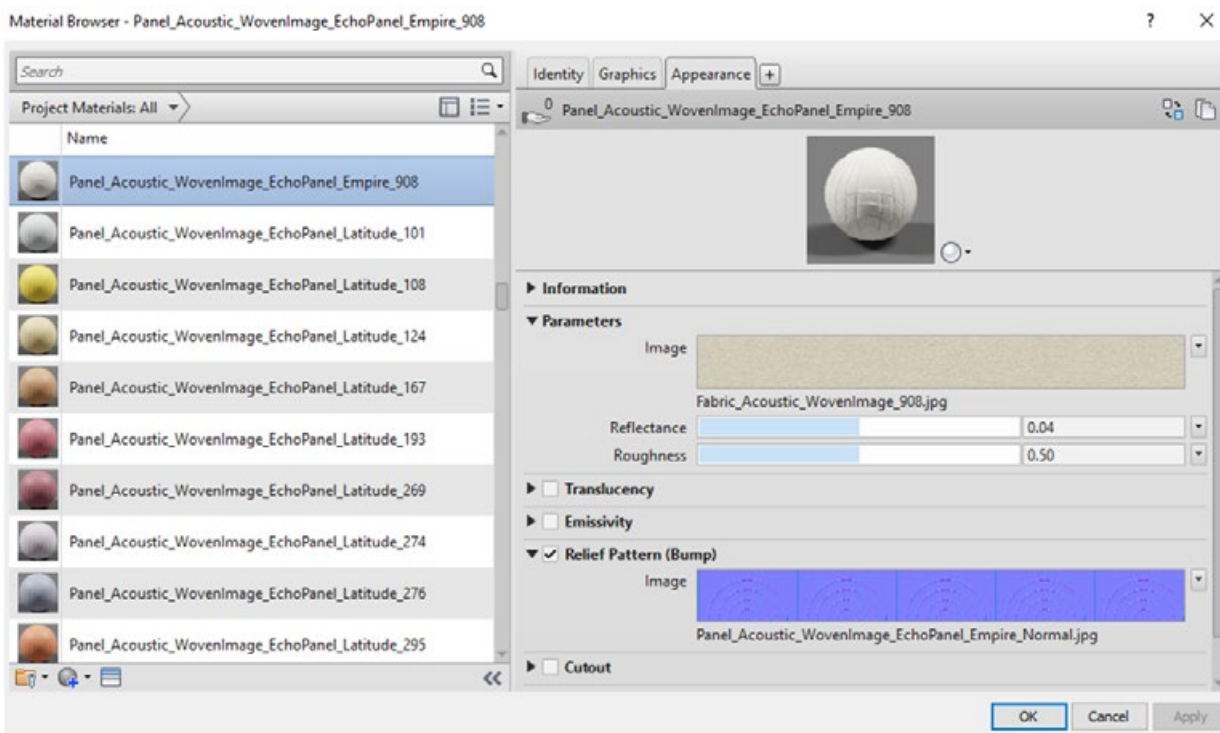

Revit materials that use custom image textures will appear grey or a flat colour without the image if the image cannot be 'found' by Revit. This means the process of downloading and linking the image folder to Revit needs to be done just once. After downloading the material texture images for the selected product range, follow the steps below to 'point' Revit to these images:

Step 1 – If your office has an existing location for material assets, copy all associated material texture images into the given folder. Alternatively, create a local folder on your computer to place all custom material assets into.

Step 2 – Once images are in the correct location, in Revit, select 'file', then select 'options'.

Step 3 – In the options dialog, select 'rendering' then the green plus '+' sign.

Step 4 – Paste the folder path from Step 1, or select the three dots, and navigate to that folder, then select 'OK'.

Once this has been completed, any previously opened views set to 'realistic' will need to be changed to 'shaded', then back to 'realistic' to see the changes. After the material images folder has been established, Steps 2, 3 and 4 do not need to be repeated for each product range, simply copy the images into the same shared folder. If multiple versions of Revit are in use, Steps 2, 3 and 4 will need to be repeated for each Revit version.

REVIT CONTENT INTRODUCTION & USER GUIDE



3.3 Loadable Acoustic Panels

All Woven Image acoustic panel ranges have been created using several families, each with their own dedicated application and workflow.

The single face-based embossed panels will follow the orientation and slope of any face or wall to which it is hosted. This version of the product represents a full-size single panel that can be cut down as required. To cover an entire wall, the single panels will need to be placed side by side either via copy/paste or the Revit array tool.

The provided **DesiredHeight** and **DesiredLength** parameters can be updated to resize the panel. The values input to these parameters are validated via the **ManufacturerOverallHeight** and **ManufacturerOverallLength** parameters to ensure a full single panel size is not exceeded.

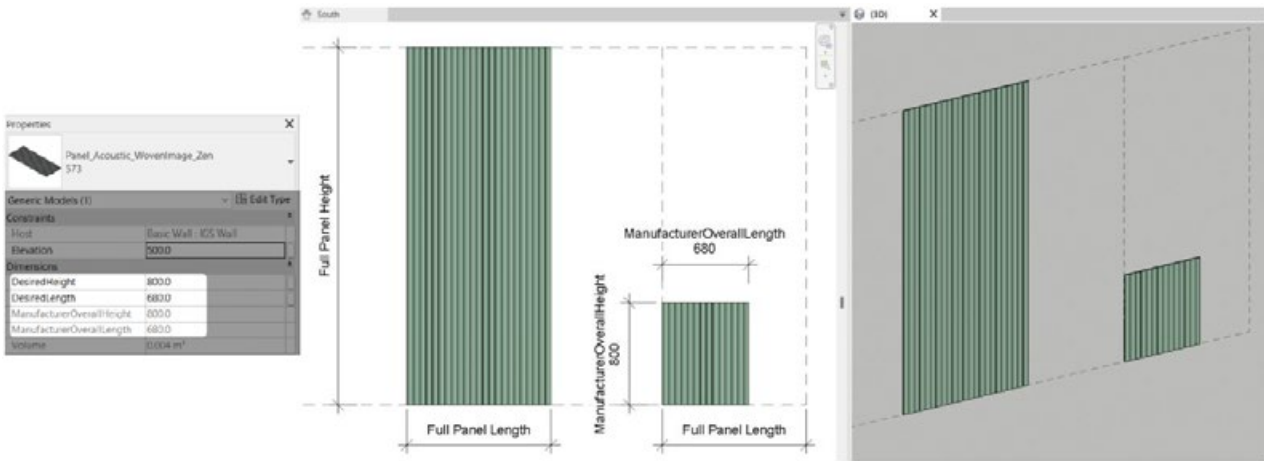

The line-based panel Array version of the acoustic panels allow for drawing a line to follow the length of any given wall or surface, with the panels arraying and resizing automatically to satisfy the specified overall length. The **DesiredHeight** parameter may be updated to create a cutdown version of the selected panel, with the input value being automatically validated via the **ManufacturerOverallHeight** parameter to ensure the height of any panel never exceeds the size of the actual product.

To cover a wall vertically, copy/paste the family and adjust the vertical offset using the **ManufacturerHeightFromFFL** parameter. Alternatively the array tool may be used in a front view to quickly generate multiple rows of vertically stacked panels.

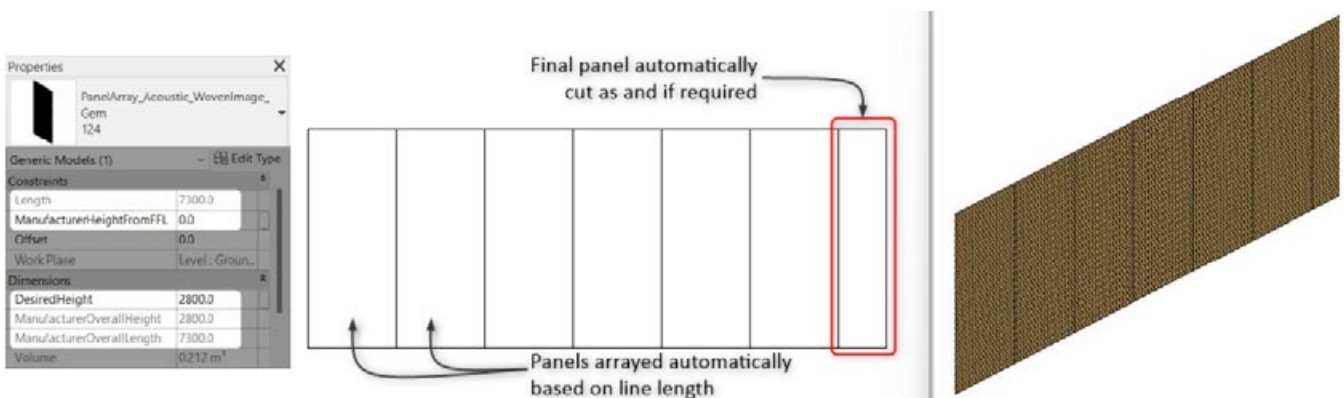

REVIT CONTENT INTRODUCTION & USER GUIDE



Finally, a material only family has been provided across all ranges for easily loading a panel material of a specific type and colour. As these families use custom created normal maps rather than detailed 3D geometry, they are a quick and lightweight alternative for applying panel materials directly to any model surface.

3.4 Array Ceiling Baffles

The following sections outline the key customisation options for the Woven Image Array baffles range of face-based acoustic ceiling baffles.

3.4.1 Control Overall System Sizing

The overall length and width of any baffle system can be defined either by inputting specific values into the provided '**DesiredOverallLength**' and '**DesiredOverallWidth**' parameters or utilising the provided grip arrows in a plan view to dynamically adjust overall system sizing.

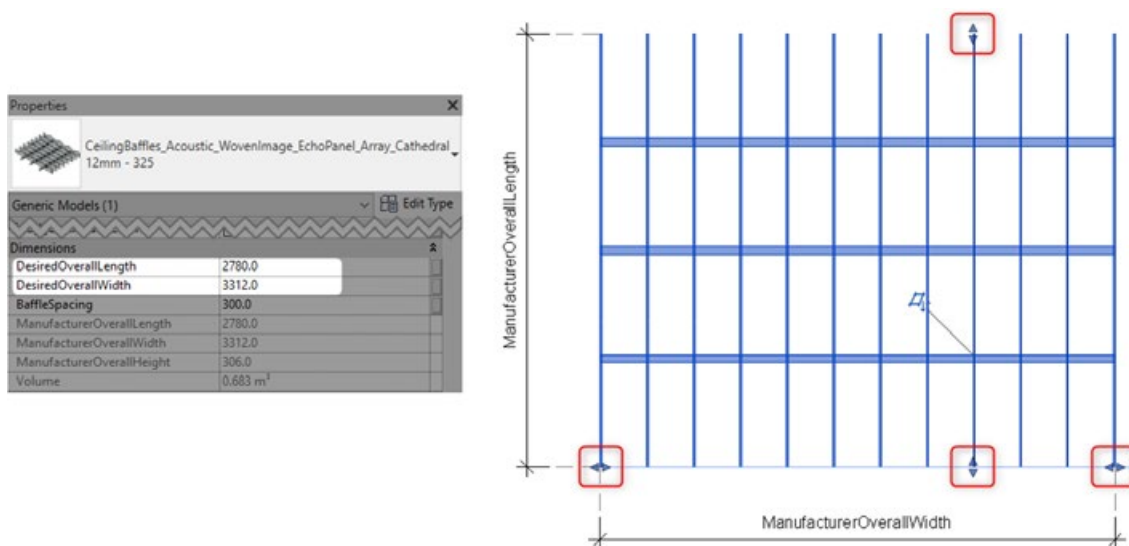

Overhanging rail ends can be adjusted to terminate at the outside face of the final baffle by using the align tool (AL) in a plan or side view. With the align tool active, first select the outermost face of the final baffle in the sequence as the alignment reference, then use the TAB key with the mouse hovering over the overhanging rail ends to select the '**DesiredRight**' reference before clicking to apply the align command.

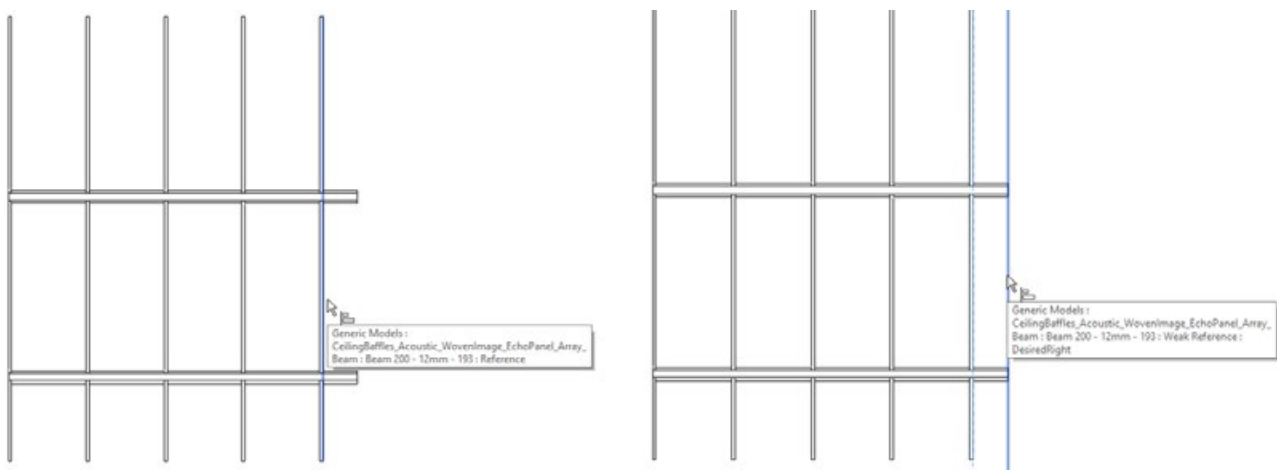

REVIT CONTENT INTRODUCTION & USER GUIDE



Please note that there may be a necessity to retain the overhanging rails in the situation where a negative detail/shadow line arrangement is desired by combining multiple instances of baffles (see Section 3.4.3). The dedicated '**BaffleSpacing**' parameter allows user input of the centre-to-centre spacings of baffle rows. Adjusting this parameter will automatically add or remove rows of baffles as required based on the specified overall system width.

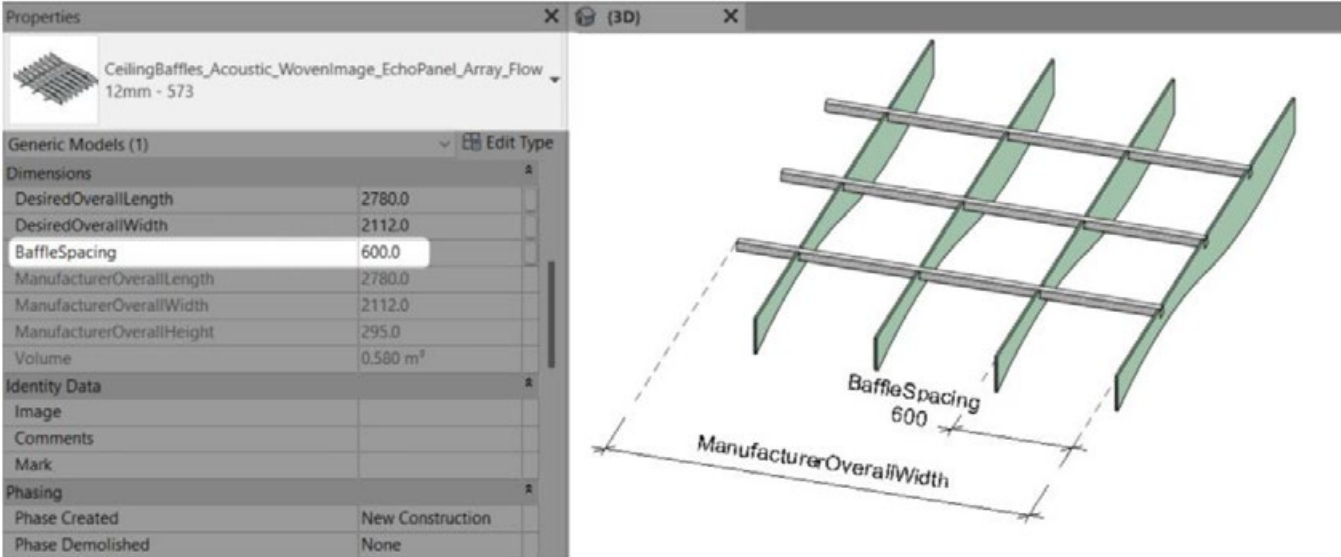
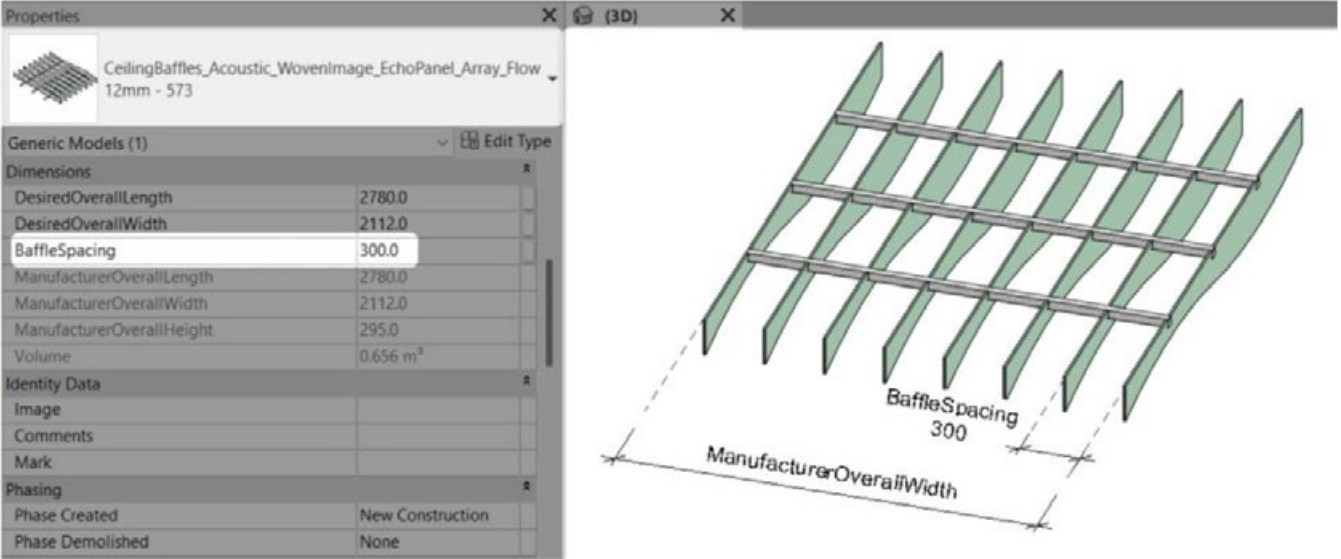

REVIT CONTENT INTRODUCTION & USER GUIDE



3.4.2 Defining Baffle Installation Type

All Array baffle families feature the '**DirectFixed**' tick box parameter that can be toggled on or off to swap between the two different installation methods.

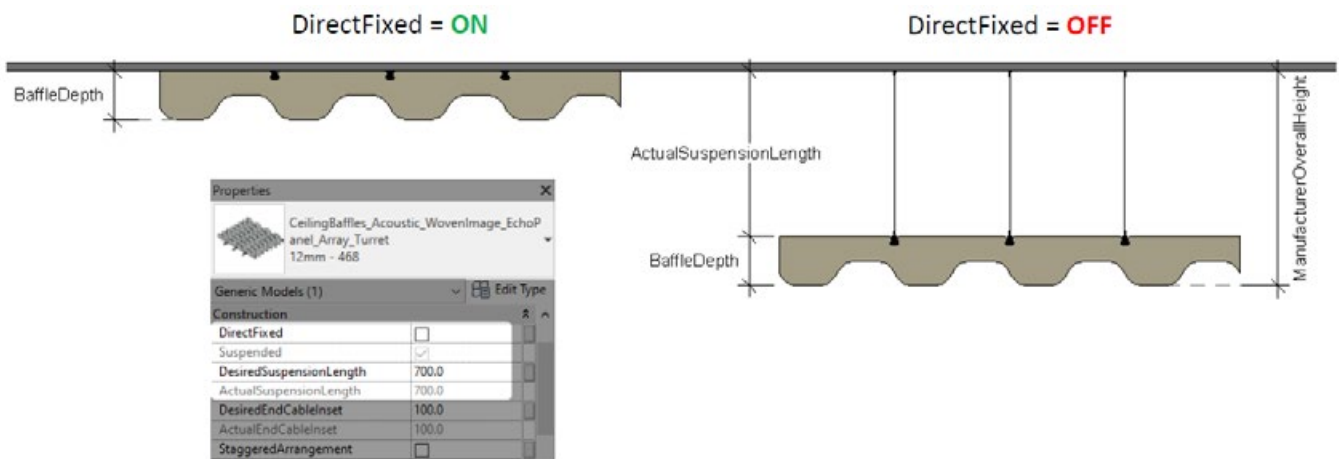

When a suspended system is specified, the '**DesiredSuspensionLength**' parameter allows input of a length value to control the suspension cable lengths i.e. the distance from the hosting face to the top of the crossrails. The input length here will be automatically validated so as to not exceed the value contained in the type-based '**RecommendedSuspensionLength**' parameter. This value has been set to 1200mm by default, however, can be increased to achieve longer suspension cables.

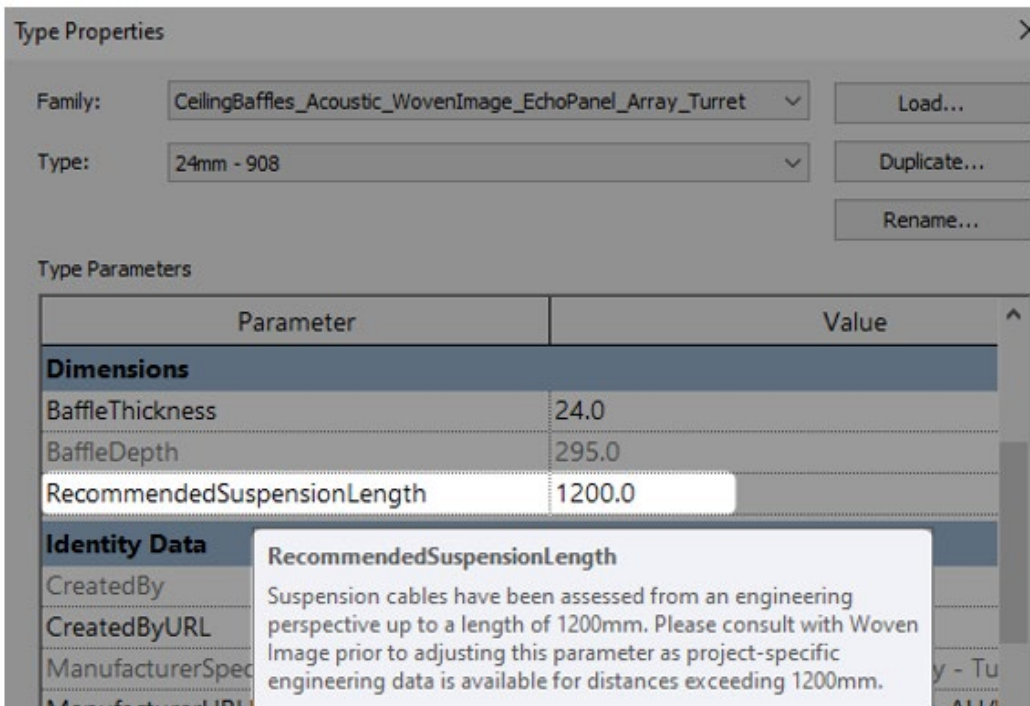

When documenting a suspended system, the position of the first and last suspension cable can be controlled via the '**DesiredEndCableInset**' parameter, which will automatically validate to remain within the allowable range.

REVIT CONTENT INTRODUCTION & USER GUIDE

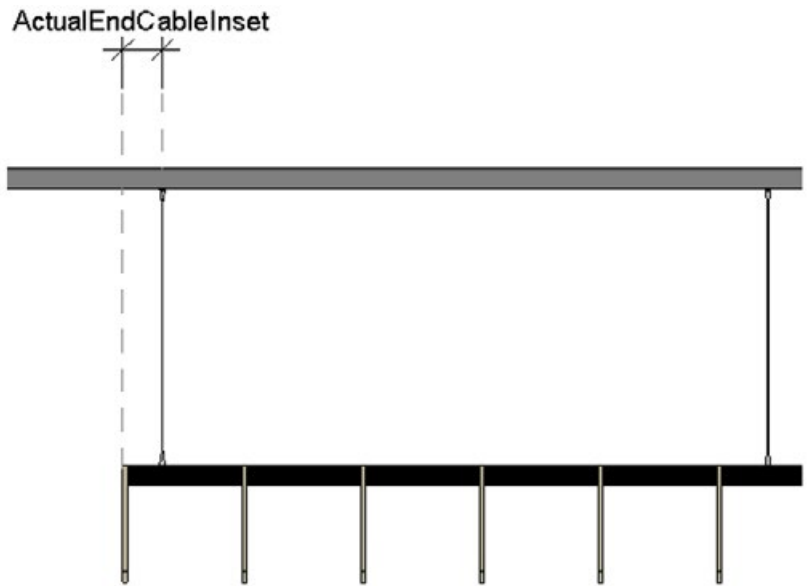
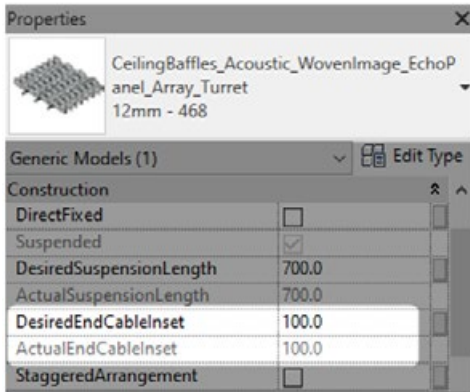

3.4.3 Updating Baffle Arrangement

For asymmetrical baffle profiles, the **'StaggeredArrangement'** tick box parameter allows for increased visual variance, providing the ability to toggle between an aligned or staggered patterning of baffles.

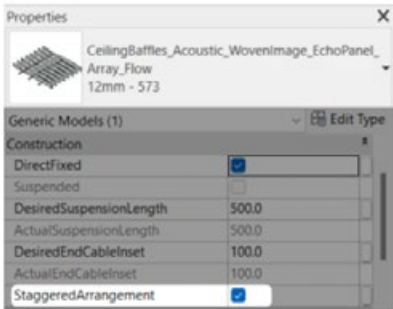

StaggeredArrangement = OFF

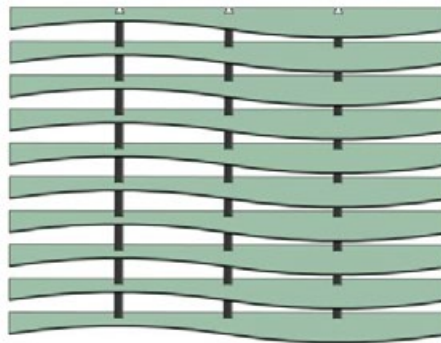

StaggeredArrangement = ON

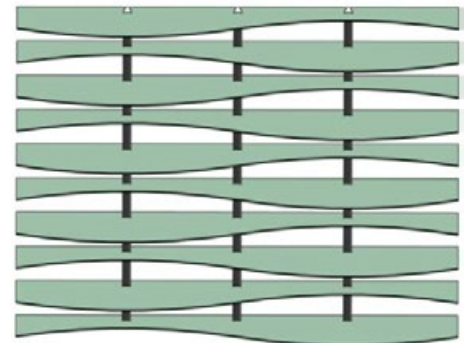

REVIT CONTENT INTRODUCTION & USER GUIDE



Multiple instances of Array baffles may be combined to achieve a negative detail/shadow line configuration, in which there are back-to-back baffles with a small gap between. This can be achieved by copying an instance of the Array baffles in the direction of the cross rails by the desired amount.

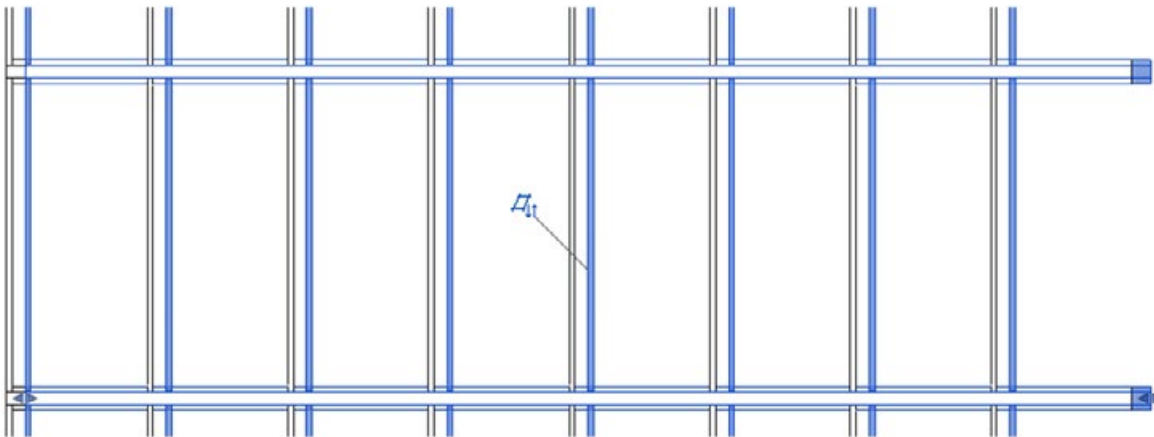

Ensure that the **'ShowCrossrails'** parameter is deactivated on this copied instance to avoid duplicate rails and cables. It is important that the installation methods and suspension lengths (if applicable) are identical across all instances used within this configuration to guarantee correct horizontal alignment. Rail ends can be adjusted to suit as per the steps outlined in Section 3.4.1.

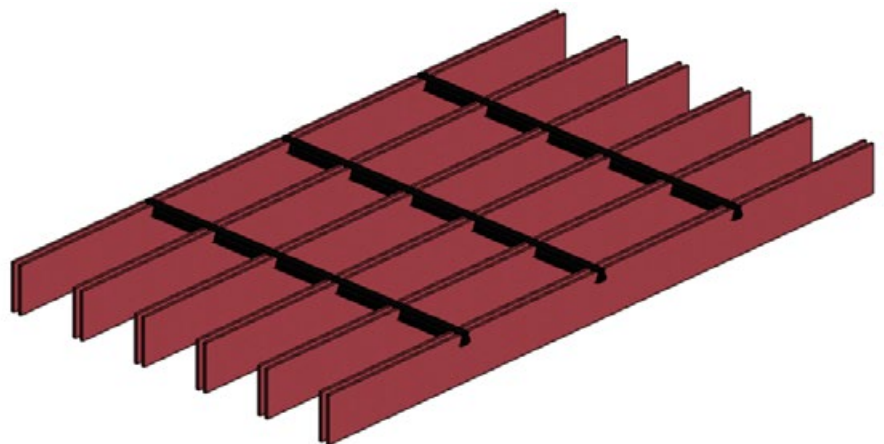
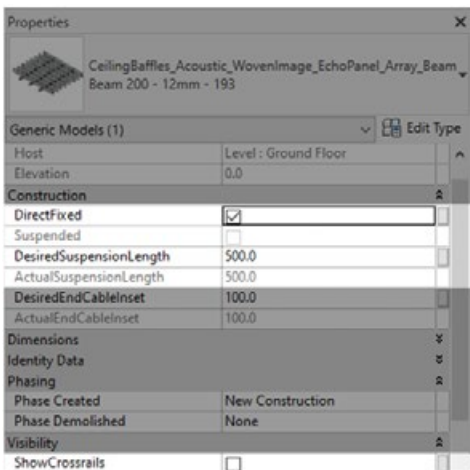

REVIT CONTENT INTRODUCTION & USER GUIDE



3.4.4 Alternating Baffle Colours

Family types exist for all available baffle thicknesses and colours across the Array product range. Further customisation is provided via the **'BaffleMaterialPrimary'** and **'BaffleMaterialSecondary'** material parameters.

By default, these parameters are set to the same value and as such all baffles will display as a consistent colour according to the family type selected. Custom types can be created using the 'duplicate type' workflow (outlined below), at which point a logical type name can be applied and the appropriate **'BaffleMaterial'** parameter changed to display alternating rows of baffles in differing colours.

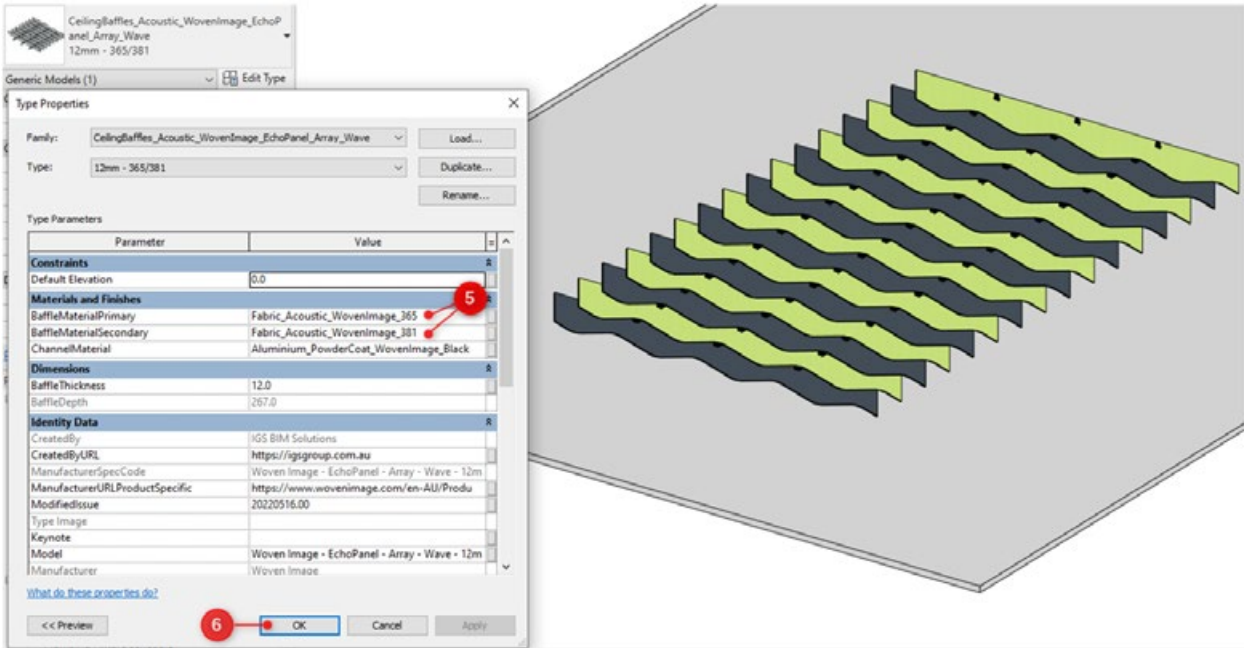
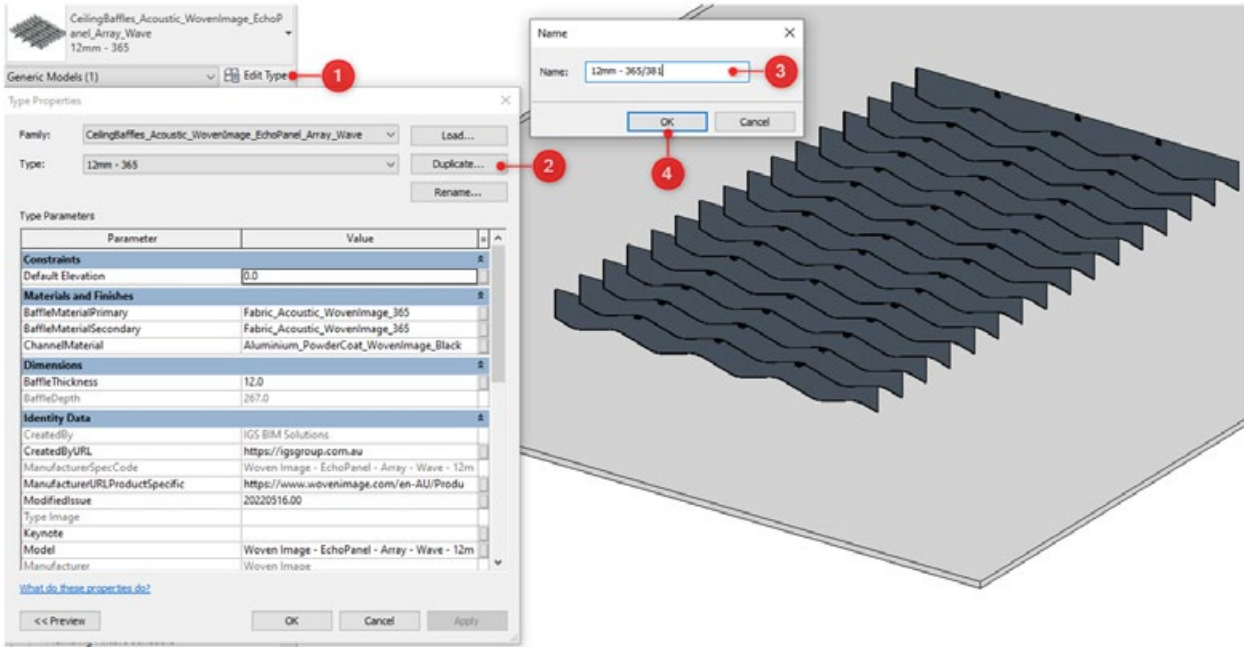

REVIT CONTENT INTRODUCTION & USER GUIDE



3.5 Fuji Ceiling Tiles

The range of Fuji tile products have been provided as non-hosted families as both an arrayable assembled system (tiles and supporting rail), and standalone componentry for the various Fuji tile sizes and rail system. The following sections outline the key customisation options for the Woven Image Fuji range of acoustic ceiling tiles.

3.5.1 Placement and Sizing

Once an instance of the Fuji arrayed tile system is placed, the **ManufacturerHeightFromFFL** parameter is able to be adjusted to define its mounting elevation e.g. underside of ceiling above.

The provided **TileQuantity** parameter allows for input of any positive integer (including '1'), which will in turn update the geometry of the component to feature additional Fuji tiles to suit. The spacings between these tiles can be adjusted using the **DesiredTileSpacing** parameter, which will automatically validate via the calculated **ActualTileSpacing** parameter to ensure tiles within the array never interact with each other.

The reported **ManufacturerOverallWidth** parameter is calculated based on the tile quantity, tile spacings, and any rail end extensions applied (see Section 3.5.2).

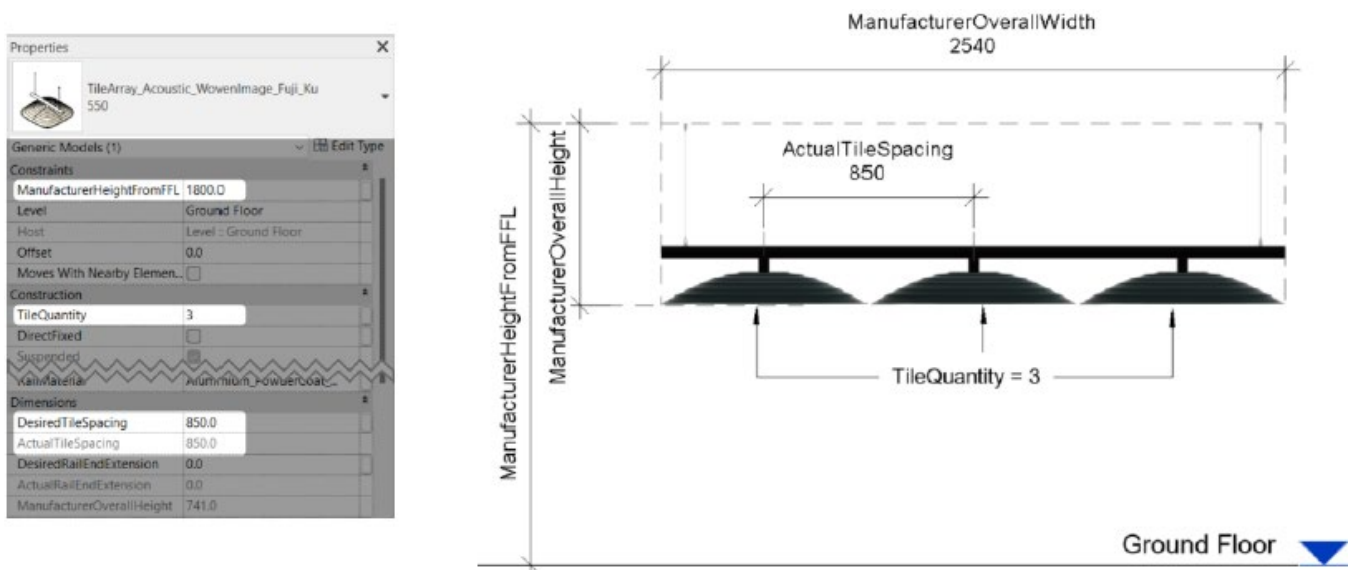

3.5.2 Defining Installation Method

The **DirectFixed** tick box parameter has been provided within all the assembled Fuji families and the standalone rail component. Activating this parameter will update the component's geometry to remove the suspension cables and automatically reposition the rail and any supported tiles to generate a direct fixed variant of the selected instance.



REVIT CONTENT

INTRODUCTION & USER GUIDE



When **DirectFixed** is not active, the family will be displayed using the suspended installation method. Multiple options are provided around the suspension conditions. **The provided DesiredSuspensionLength** allows for inputting the desired suspension cable **length**, which is automatically validated via the **ActualSuspensionLength** parameter.

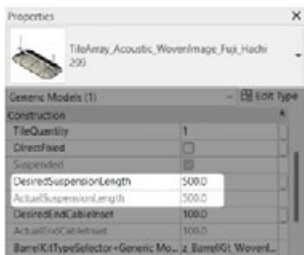

The **DesiredRailEndExtension** parameter allows for defining the length that the supporting rail extends from the outer edges of the end most Fuji tiles. The input value to this parameter can be either negative or positive to alter the direction that the rail end moves. The input value will be automatically validated via the **ActualRailEndExtension** parameter to ensure the rail end is never inset enough to result in an unsupported Fuji barrel kit.

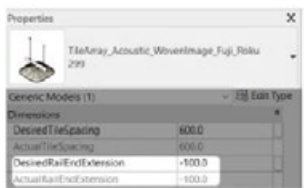
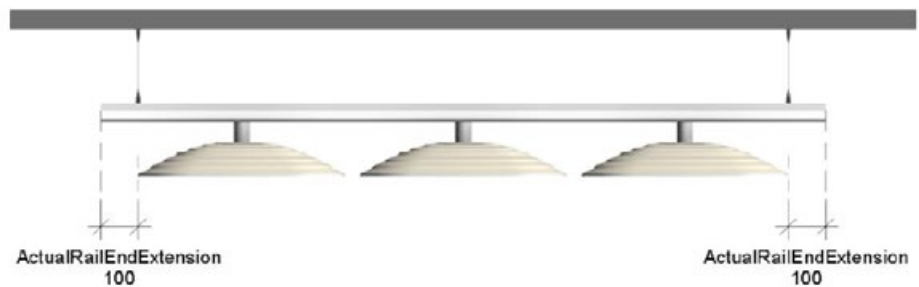
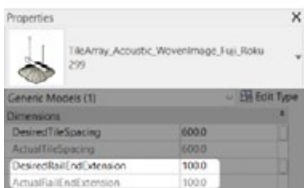

When documenting a suspended system, the position of the first and last suspension cable can be controlled via the **DesiredEndCableInset** parameter, which will automatically validate to remain within the allowable range.

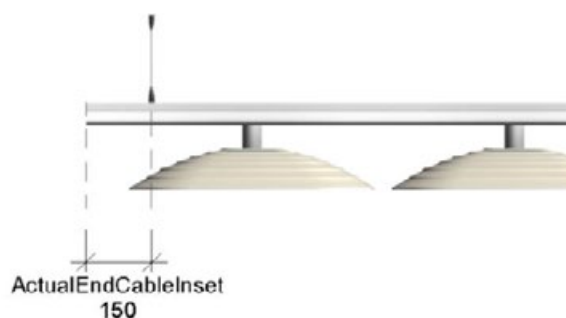
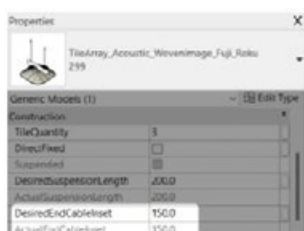

REVIT CONTENT INTRODUCTION & USER GUIDE



3.5.3 Barrel Kit Options

The **BarrelKitTypeSelector** parameter allows for instance-based control over the connecting barrel kit that integrates with the supporting rail geometry. Making a selection from the drop-down options within this parameter will allow for swapping between the 3 available standard colour combinations of barrel kit. Please note, it is important to ensure to only choose one of the 3 types within the 'z_BarrelKit_WovenImage_Fuji' family.

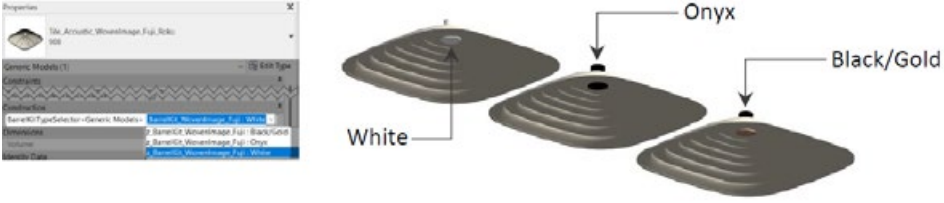

3.5.4 Standalone Rail & Tile Components

The standalone components (Fuji tiles and rail) are intended to be used for more bespoke designs where variations in Fuji tiles, colours, or tile rotation along the length of a single supporting rail are required. This method allows for flexible placement of individual tile components along a shared supporting rail element. The placement and options around installation method for the standalone Fuji rail are identical to that of the arrayed version (outlined in Section 3.5.1 and Section 3.5.2). One key exception is that the length of the rail is not automatically controlled based on the quantity of tiles, but rather requires user input to the **ManufacturerOverallLength** parameter.

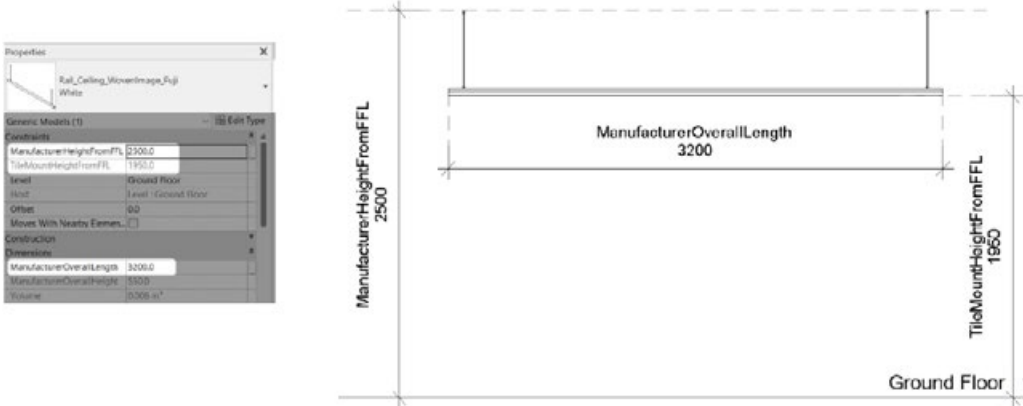

The calculated **TileMountHeightFromFFL** within the Fuji rail family allows for easy vertical alignment of standalone Fuji tiles to the rail's underside. The **ManufacturerHeightFromFFL** of the Fuji tiles should be updated to match the **TileMountHeightFromFFL** value of the supporting rail.



REVIT CONTENT INTRODUCTION & USER GUIDE



3.5.5 Applying Custom Colours

Beyond the 4 x standard colour options for each Fuji tile, a dedicated 'Custom' family type has been included as a starting point for creating non-standardised colour combinations. The steps below demonstrate the suggested workflow for achieving custom colour Fuji tiles. This workflow is identical for both the arrayed assembled Fuji families and the standalone Fuji tile families.

Firstly, place an instance of the 'Custom' family type from within the desired Fuji tile family.



Select this newly placed Custom Fuji system/tile and access the Edit Type dialogue (1). From here, duplicate the type (2) and rename the desired colour(s) to be applied to the tile (3). Once the type has been duplicated, update the **TileTopMaterial** and **TileBottomMaterial** parameters with the appropriate fabric colour materials available within the Woven Image Virtual Showroom file (4). Select OK to apply all changes and reveal the custom Fuji tile solution (5).

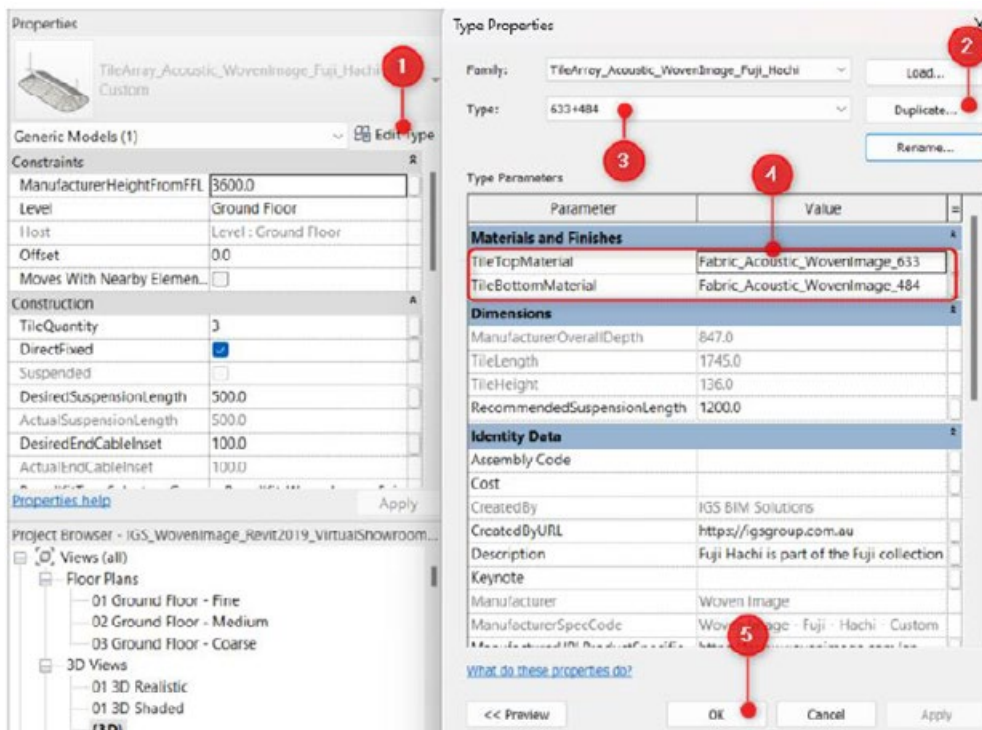

REVIT CONTENT INTRODUCTION & USER GUIDE



4.0 CLOSING STATEMENT

The overarching goal in creating this Woven Image Revit content library is to increase the ease in which Revit users can design, document, and specify Woven Image products within the Revit environment. Woven Image is committed to the continued development of this Revit content library as the industry and BIM workflows evolve over time.

We welcome your feedback and insights to ensure we can continue to accommodate your Revit content requirements.

