

3D FORMED PANELS

INSTALLATION GUIDE

This guide is presented in good faith to assist in the installation of 3D formed panels. It is not intended as an all-encompassing guide, and a professional qualified installer is recommended for optimum results.

Woven Image accepts no responsibility for installation actions taken or not taken. Please refer to Woven Image Pty Ltd. Terms of Trade.

This installation guide contains only recommendations; if you have any questions about installation techniques please contact your distributor or Woven Image representative.

Please note:

- Allow for thickness variations due to manufacturing tolerances and any minimal unevenness of substrate.
- Exact colour matching cannot be guaranteed between batches.
- Fibre mix and surface texture may vary.
- Please check that all panels are the correct design, colour, shape and batch number (if requested).
- Stickers with the Woven Image logo are placed in the same corner of each plain panel to assist with correct panel orientation.
- No claims will be accepted after panels are installed.
- Ensure appropriate work safety regulations are met, e.g. protective clothing, eyewear and respiratory equipment.

HANDLING & STORAGE

Carry boxes and panels **upright**

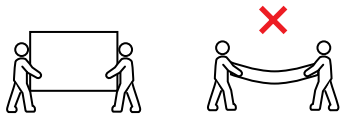

Store in a **cool dry** place, with **no direct sun**.
Avoid **65°C or greater**

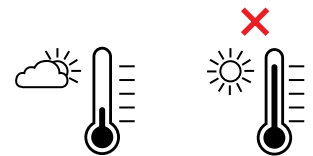

Store boxes and panels **flat**

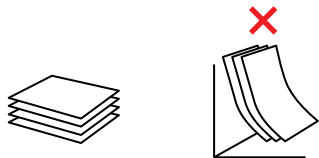

Keep all **surfaces clean** for storage and fabrication

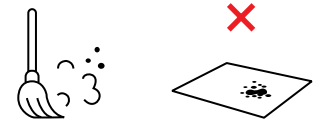

Wear **gloves** for handling **light colours**



Upon delivery, **inspect** all goods for order **correctness** and **damage**

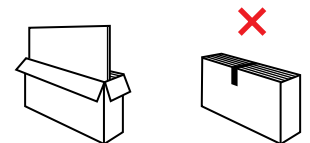

Keep **dry** and **avoid humidity**

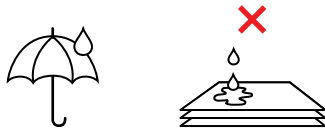

Protect the **edges**



3D FORMED PANELS

INSTALLATION GUIDE

INSTALLATION

This guide is for direct fix wall application via edge to edge butt joining and utilising an optional aluminium edge trim.

Column and Curtain are non-woven products that can vary by up to 7% in thickness which is a natural characteristic of this material. The 3D formed shapes can therefore vary in depth and -5mm/+10mm in width from panel to panel.

Cutting/trimming by machine

- 3D formed panels can be cut on a CNC machine or using a plunge cut circular saw or band saw with wave toothing blade and a metal guide.
- Do not use a serrated blade with side-set teeth.
- Trial cut on a scrap piece first, as saws will behave differently on sheets of different thickness and density.
- Feed against the rotation of the blade or tool using a slow, consistent feed rate to prevent overheating.
- A fast feed can cause frictional heat which can melt or fuse the heated contact points with a saw blade.
- Secure sheet whilst cutting to minimise vibration.

Cutting/trimming by hand

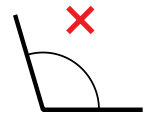
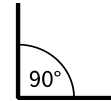

- Ensure blade is inserted into panel at 90° to the surface to ensure square edges and best results for butt joins.
- Ensure the blade is sharp and not too long or flexible to avoid skew cuts.
- Replace the blade often to maintain sharpness.

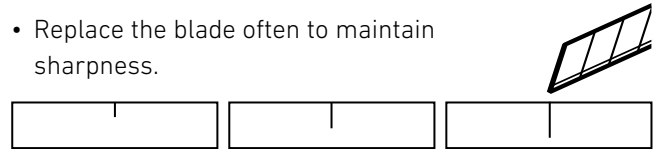

- For best results, use multiple cuts and light pressure.
- Keep flat and use a backing mat.
- Use a secure straight edge for straight cuts.

Fixing and adhesives

- 3D formed panels can be direct fixed with a commercial adhesive. It is the installer's responsibility to ensure the adhesive used is appropriate for the product and substrate it is being fixed to.
- Prepare the site with a clean drop sheet and place the panels face side down on the floor.
- Ensure the wall or ceiling surface is clean and free of dust or imperfections that could prevent adhesion. Industry standard of drywall Level 3 is recommended.
- Panels may easily flex. To avoid creasing, ensure they are well supported by a minimum of two people when positioning vertically to the substrate.
- Adhesives should be used as per the manufacturer's instructions, and it is advised to perform a test piece prior to full installation.
- When using adhesives, position the panel to the substrate and apply even gentle pressure. Ensure to use minimum pressure at the edges to avoid adhesives showing. See the following pages for recommended adhesive distribution.

- 3D formed panels may be directly screw fixed to the prepared wall. Although there is no set formula for fixing spans, apart from carefully taking into account the concave and convex nature of the design, it is reasonable to expect that fixing between 250mm and 300mm centres horizontally and 650mm and 700mm centres vertically would allow the panel to remain rigid in most circumstances.

The use of washers may assist with load distribution and a clean finish.

Seams and panel edge management

- Seams and panel edges may be finished with the addition of an optional off-the-shelf or Woven Image supplied aluminium T-Joiner or 9mm edge trim, see page 5 for further installation instruction.

Double height installation

- Due to the complex curvature of the 3D formed series, Woven Image does not recommend double height installation of these products.

3D FORMED PANELS

INSTALLATION GUIDE



WOVEN IMAGE®

INSTALLATION

When direct fixing panels to walls it is recommended to apply adhesive at 250-300mm centres on parts of the panel that will directly contact the wall, as pictured in the diagrams below:

COLUMN

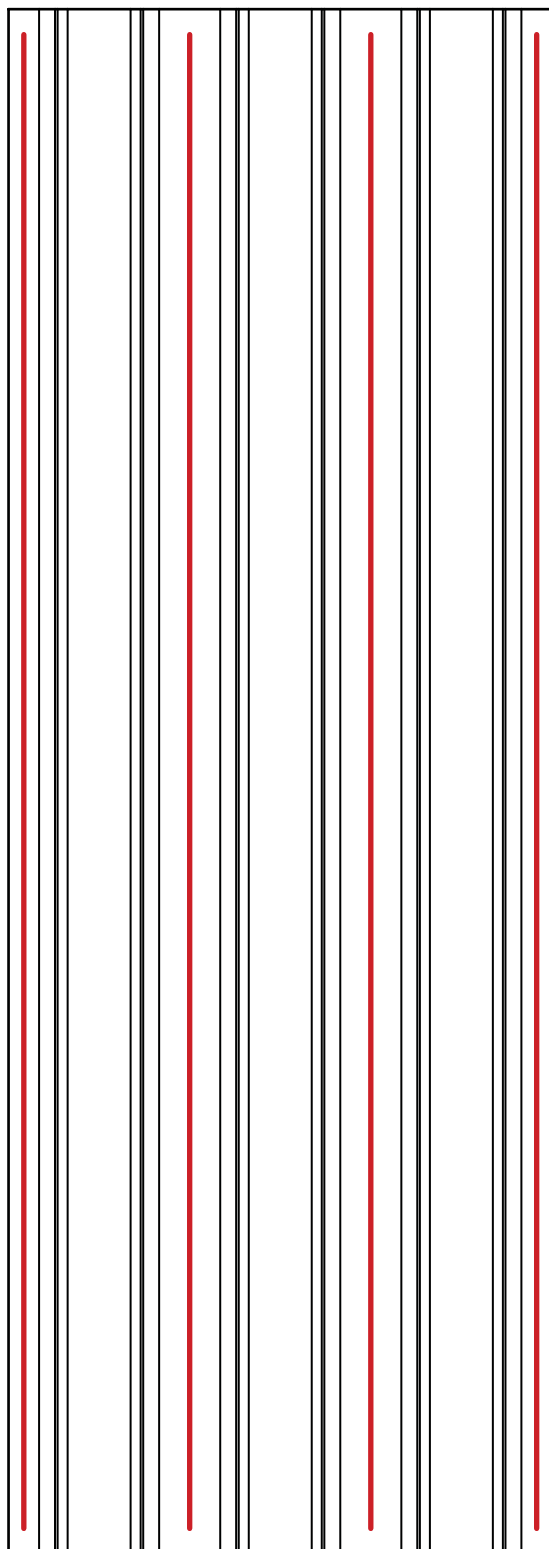

CURTAIN

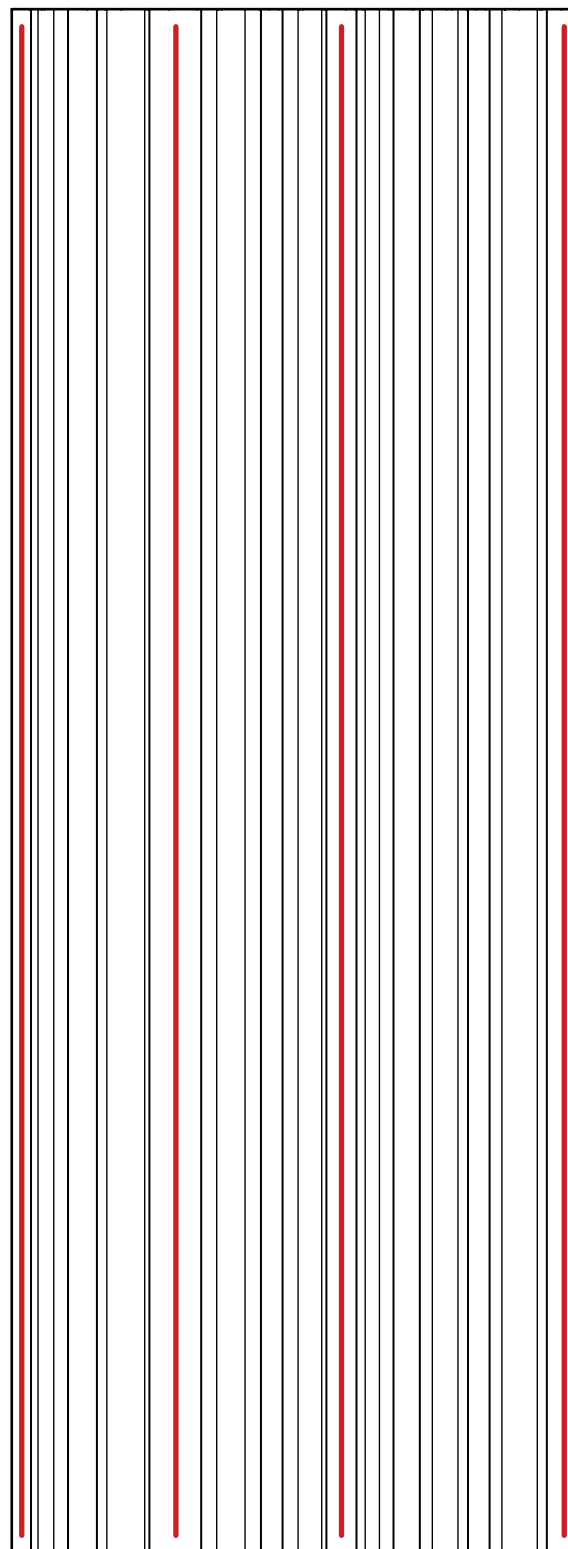

3D FORMED PANELS

INSTALLATION GUIDE

COLUMN

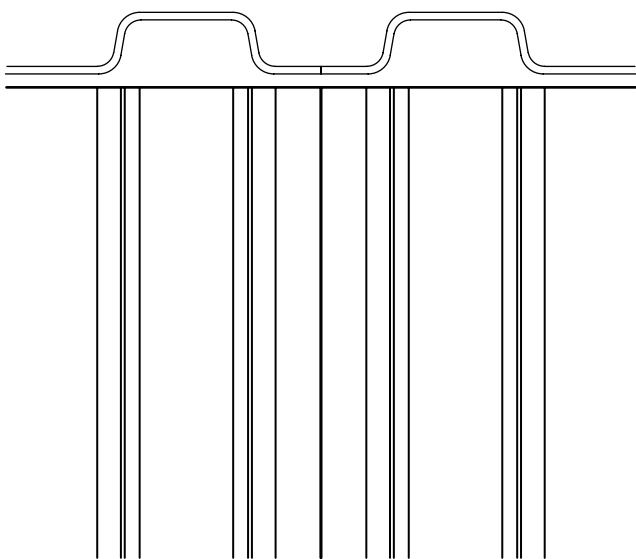
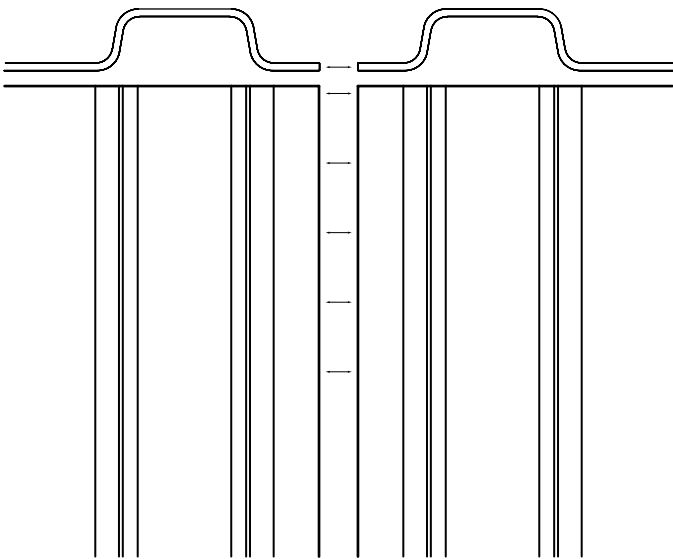
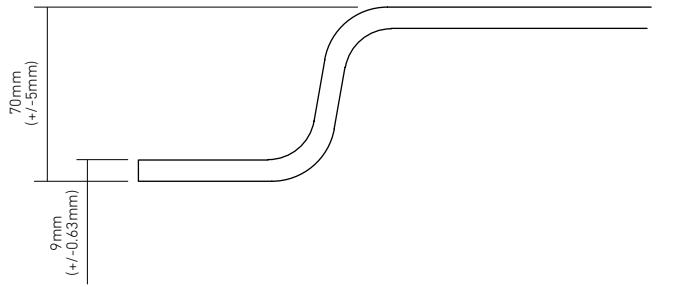

CURTAIN

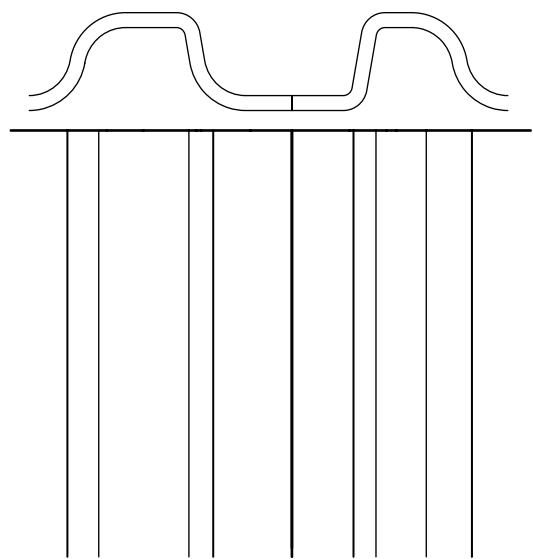
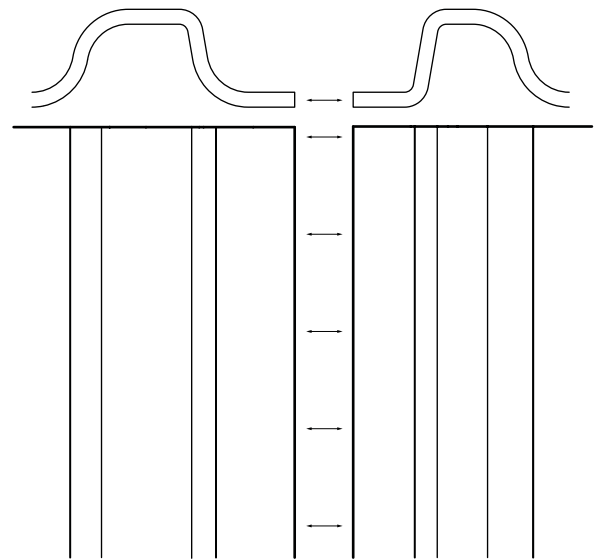
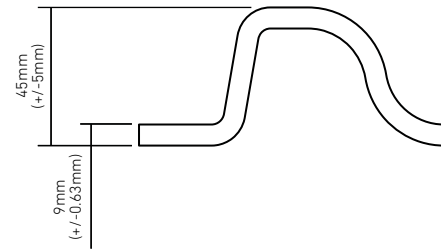

3D FORMED PANELS

INSTALLATION GUIDE

TRIM PROFILES

Woven Image trim profiles come in 3000mm lengths, these can be easily trimmed on site using an appropriate drop saw or hack saw to match the height of the panel install.

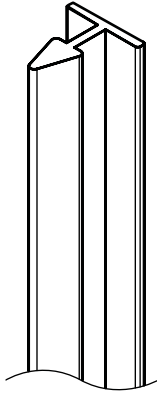

T-Joiner

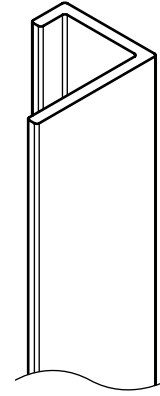

9mm edge trim

9mm EDGE TRIM

The 9mm edge trim is used to cover the edges of 3D formed panels at the end of a wall. Prior to fixing the panel to the wall, friction fit the trim onto the edge of the panel. Proceed with install of the panel as per the instructions on the previous pages.



T-Joiner

The T-Joiner can be easily installed between two panels that have been direct fixed to the wall. After ensuring the joiner runs the full length of the join, simply press the piece into the gap between the panels. The shape of the joiner will ensure a snug friction fit.

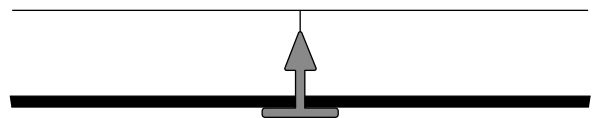
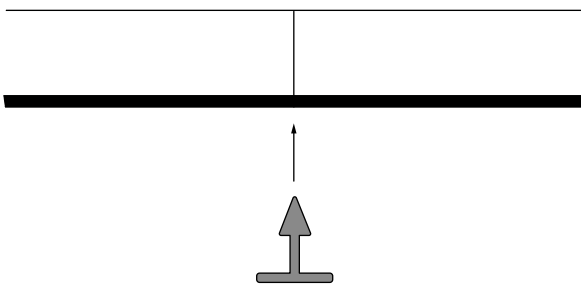

3D FORMED PANELS

INSTALLATION GUIDE

T-JOINER AND EDGE TRIM (shown on Column)

